

### Installation Instructions

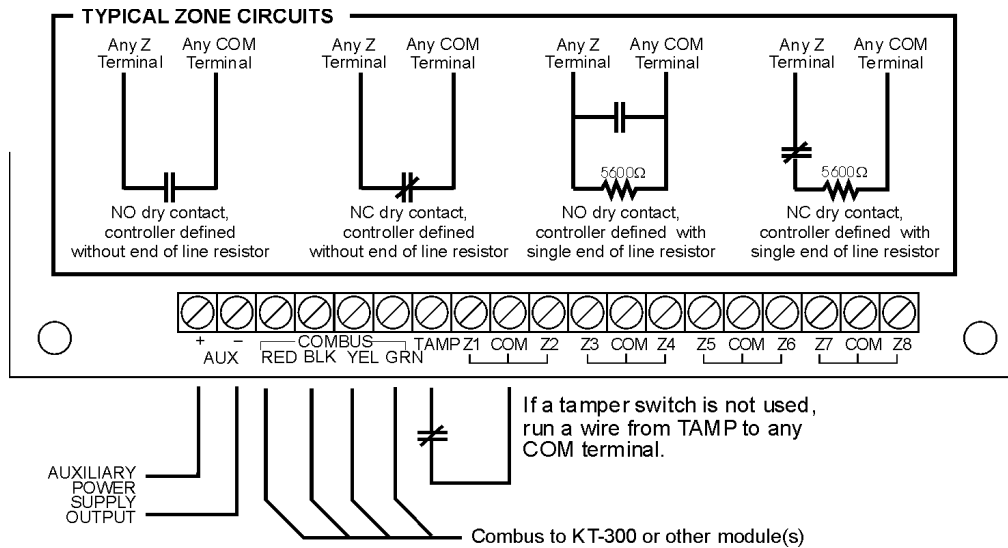

#### 1. Introduction

The **KT-PC4108** is a zone input module that adds up to 8 fully programmable zones to the **KT-300** door controller.

#### 2. Specifications

- Connects to the controller via 4-wire Combus
- Current Draw: 30 mA (from Combus)
- Supports single end-of-line (5600 ohm resistors) and no end-of-line zone loops.
- AUX+ output: 12VDC, 250mA max. (drawn from Combus)
- Tamper contact input

#### 3. Installing the KT-PC4108 module

##### 3.1 Unpacking

The **KT-PC4108** package includes the following parts/items:

- One (1) KT-PC4108 circuit board
- Sixteen (16) end of line resistors (5600 ohms)
- Four (4) plastic standoffs
- One (1) installation instructions sheet

##### 3.2 Mounting

The **KT-PC4108** should be located inside a compatible cabinet (Kantech part no. KT-4051CAB), mounted in a dry, secure location. Preferably, it should be placed at a convenient distance from the connected devices.

Perform the following steps to mount the unit:

- 1) Press the four (4) plastic standoffs through the mounting holes on the back of the cabinet,
- 2) Secure the cabinet to the wall in the desired location. Use appropriate wall anchors when securing the cabinet to drywall, plaster, concrete, brick or other surfaces,
- 3) Press the circuit board into the four (4) plastic standoffs to secure the module to the cabinet.

##### 3.3 Installation and Wiring

Before beginning to wire the unit, ensure that all power (AC transformer and battery) is disconnected from the controller.

Perform the following steps to complete wiring:

- 1) Connect the four Combus wires to the KT-PC4108. Connect the red, black, yellow and green Combus wires to the RED, BLK, YEL and GRN terminals, respectively,
- 2) Complete all zone wiring to the zone input terminals (Z1-Z8). See the KT-300 Installation Manual for details on zone wiring configurations,
- 3) Connect the external tamper switch, if used.

Consult the above wiring diagram for further information.

##### 3.4 Applying Power

After all wiring is completed, apply power to the controller. Connect the battery leads to the battery, then connect the AC transformer.

**Note:** Do not connect the power until all wiring is complete.

#### 4. Assigning the module

Once all wiring is complete, the module must be assigned to the system. To assign the module, perform the following steps:

- 1) Establish communication between the PC and the controller,
- 2) Remove the tamper switch wire (or only the wire if tamper switch is not used),
- 3) A serial number should be displayed on the screen, in the same window where is the serial number is located, you should see the type of module and on which controller it is connected,
- 4) From the software, select the functionality of the module and enter the serial number in the appropriate field (see your software reference manual under controller definition -- Assigning modules for more details).

**Note:** Don't forget to reconnect the tamper switch (or the wire, if there is no tamper switch)

## Terminal Connections

Module no.: \_\_\_\_\_

Date of installation: \_\_\_\_\_

KT-300 NAME: \_\_\_\_\_

KT-300 SITE NAME: \_\_\_\_\_

KT-300 SERIAL NUMBER: \_\_\_\_\_

AUX: \_\_\_\_\_

COMBUS (FROM): \_\_\_\_\_

COMBUS (TO): \_\_\_\_\_

Z1 (Z9): \_\_\_\_\_

Z2 (Z10): \_\_\_\_\_

Z3 (Z11): \_\_\_\_\_

Z4 (Z12): \_\_\_\_\_

Z5 (Z13): \_\_\_\_\_

Z6 (Z14): \_\_\_\_\_

Z7 (Z15): \_\_\_\_\_

Z8 (Z16): \_\_\_\_\_

**Note:** Zones 1 to 8 are named zones 9 to 16 in your software.

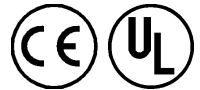

### FCC & IC COMPLIANCE STATEMENT

**CAUTION:** Changes or modifications not expressly approved by Kantech Systems Inc. could void your authority to use this equipment. This equipment generates and uses radio frequency energy and if not installed and used properly, in strict accordance with the manufacturer's instructions, may cause interference to radio and television reception. It has been type tested and found to comply with the limits for Class B device in accordance with the specifications in Subpart "B" of Part 15 of FCC Rules, which are designed to provide reasonable protection against such interference in any residential installation. However, there is no guarantee that interference will not occur in a particular installation. If this equipment does cause interference to television or radio reception, which can be determined by turning the equipment off and on, the user is encouraged to try to correct the interference by one or more of the following measures:

- Re-orient the receiving antenna
- Relocate the alarm control with respect to the receiver
- Move the alarm control away from the receiver
- Connect the alarm control into a different outlet so that alarm control and receiver are on different circuits.

If necessary, the user should consult the dealer or an experienced radio/television technician for additional suggestions. The user may find the following booklet prepared by the FCC helpful: "How to Identify and Resolve Radio/Television Interference Problems". This booklet is available from the U.S. Government Printing Office, Washington, D.C. 20402, Stock # 004-000-00345-4. This device complies with Part 15 of the FCC rules. Operation is subject to the following two conditions: (1) this device may not cause harmful interference, and (2) this device must accept any interference received including interference that may cause undesired operation. This class B digital apparatus meets all requirements of the Canadian Interference Causing Equipment Regulations. The KT-300 is also compliant with EN55022: 1994, amendment 1: 1995, Class B.